

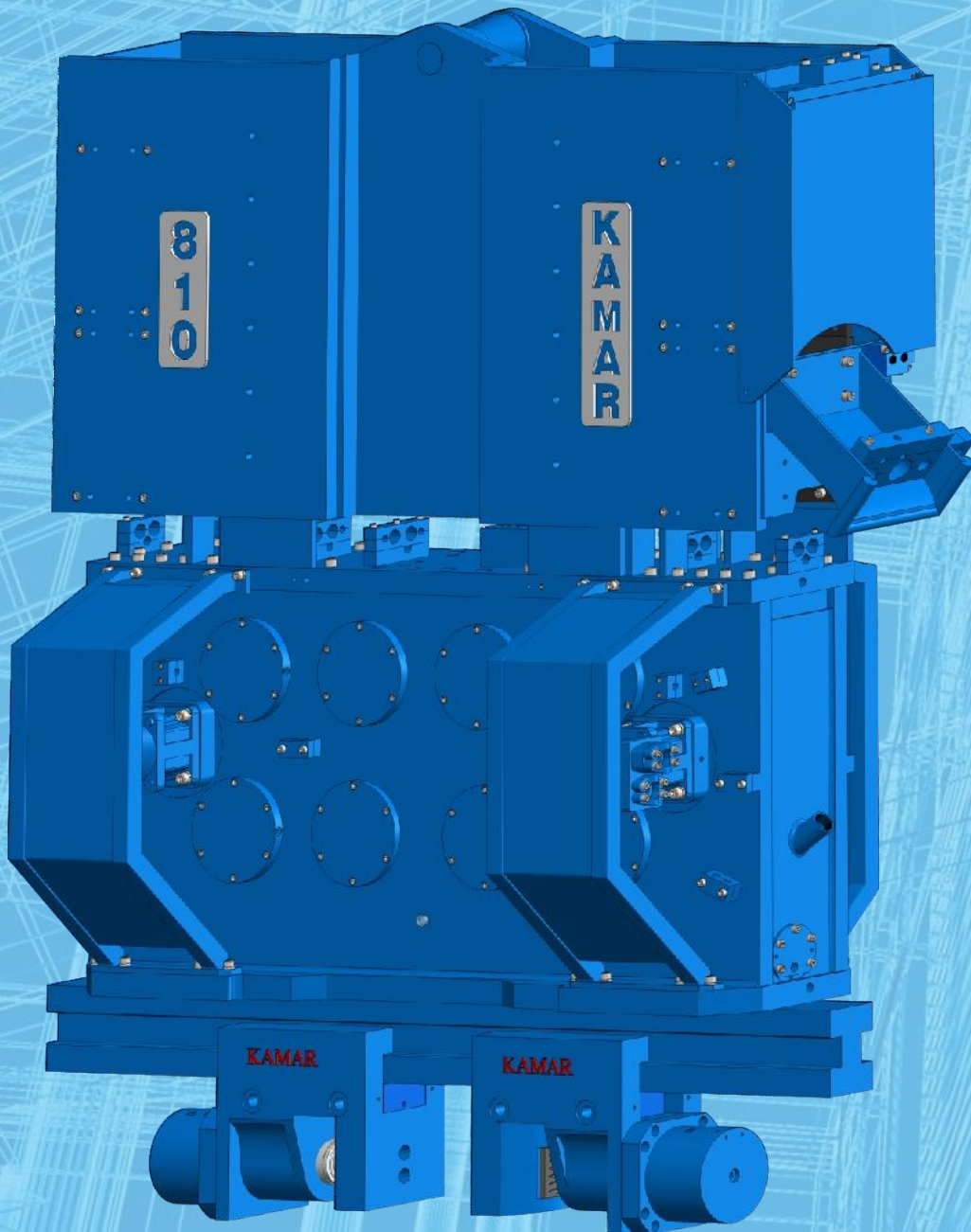

ASIA'S ONE STOP FOUNDATION SHOP

# KAMAR VIBRATORY HAMMERS

SALES • RENTAL • PARTS • SERVICE





# KAMAR INFRASTRUCTURE PVT. LTD.

KAMAR INFRASTRUCTURE PVT. LTD. began in 2005 continuing a tradition of innovation. Today, we continue to dominate the Asian market for vibratory driver/extractors with its line of powerful and more reliable hydraulic powerpacks. Our in-house brand **KAMAR** and its logo is a trademark of assurance and confidence that is very well recognised in the local construction industry. Each **KAMAR** vibratory driver/extractors and powerpacks provides impressive driving and pulling capabilities.

In recent years, we have developed the capability of building our own hydraulic powerpacks to meet the harsh and humid conditions of construction sites of this generation. The combined configuration offers contractors significant economies with the ability to meet a diversity of requirements with one hammer with multiple energy ratings.

Kamar Infrastructure's past triumphs continues a tradition of commitment to manufacturing and marketing the very best pile driving equipment anywhere. Our principles of simplicity of design, reliability of performance and durability for exceptionally long service life continue to be central to our business. These values resonate with contractors and engineering firms worldwide.

Every **KAMAR** equipment has been the result of listening to and working in partnership with customers. For decades, Kamar Infrastructure has responded time after time: inventing and perfecting tools and equipment to meet customers' requirements for advanced solutions to seemingly impossible technical challenges.

Kamar Infrastructure's attention to customer service continues to perfect its lines of equipment and interchangeable components. The goal, to enable customers to accomplish more at lower cost with their investment in **KAMAR** equipment.

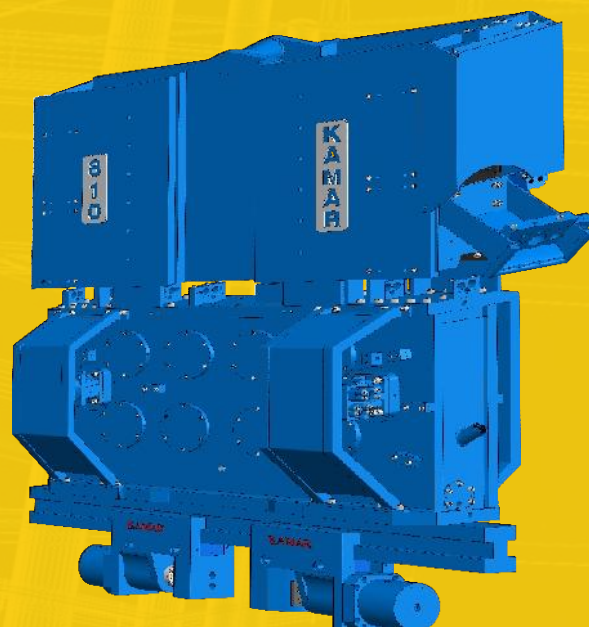

# KVH-810 HYDRAULIC VIBRATORY HAMMER

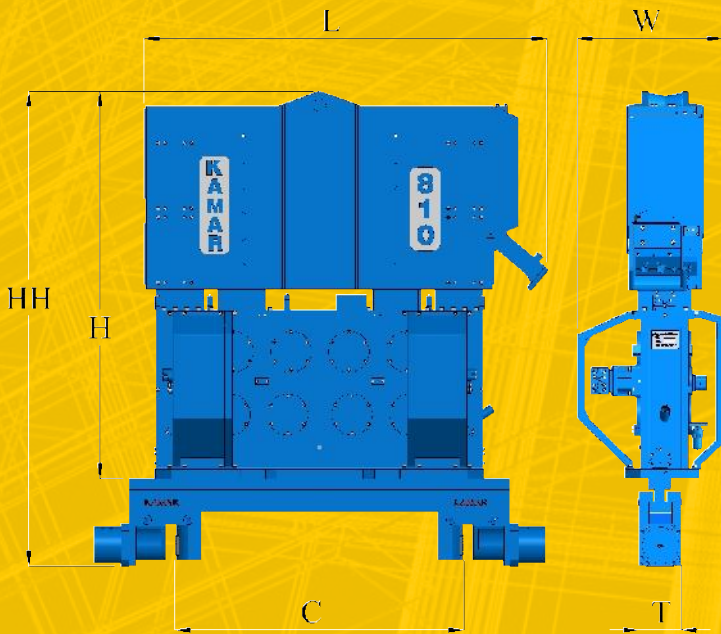

Eccentric Moment	4,400 in-lbs (50.7 kgm)
Frequency	1600 vpm
Centrifugal Force	160 tons (1427 kN)
Amplitude (free Hanging)	1.17 in (30 mm)
Max Line Pull For Extracting	50 US ton (454 kN)
Weight (no Clamps & Hoses)	13,260 lbs (6015 kg)
Non-vibrating Weight	4,000 lbs (1815 kg)
Height without Clamp (H)	100 in (2540 mm)
Height with Clamp (HH)	123 in (3226 mm)
Length (L)	105 in (2667 mm)
Width (W)	38 in (965 mm)
Throat Width (T)	12.2 in (310 mm)
Hydraulic Hose Length	150 ft (45 m)
Hydraulic Hose Weight (w/o Oil)	1,700 lbs (770 kg)
Max. Casing Dia. (C)	75 in (1900 mm)

# KPP-630 POWERPACK



Engine: Cat 3408  
 Max. Drive Flow: 620 Litres / Min  
 Max. Drive Pressure: 320 Bar  
 Power: 600 Hp  
 Operating Speed: 2100 Rpm

- Stainless Steel Latches & Hinges
  - Noise Reduction Panel
  - External Fuel & Hydraulic Tank Inspection
- Allocations
- 3800 (l) X 1650 (b) X 1900 (h)
  - 7 Ton (approx)

# CLAMPS

## K-126S HYDRAULIC UNIVERSAL CLAMPS FOR SHEET PILE

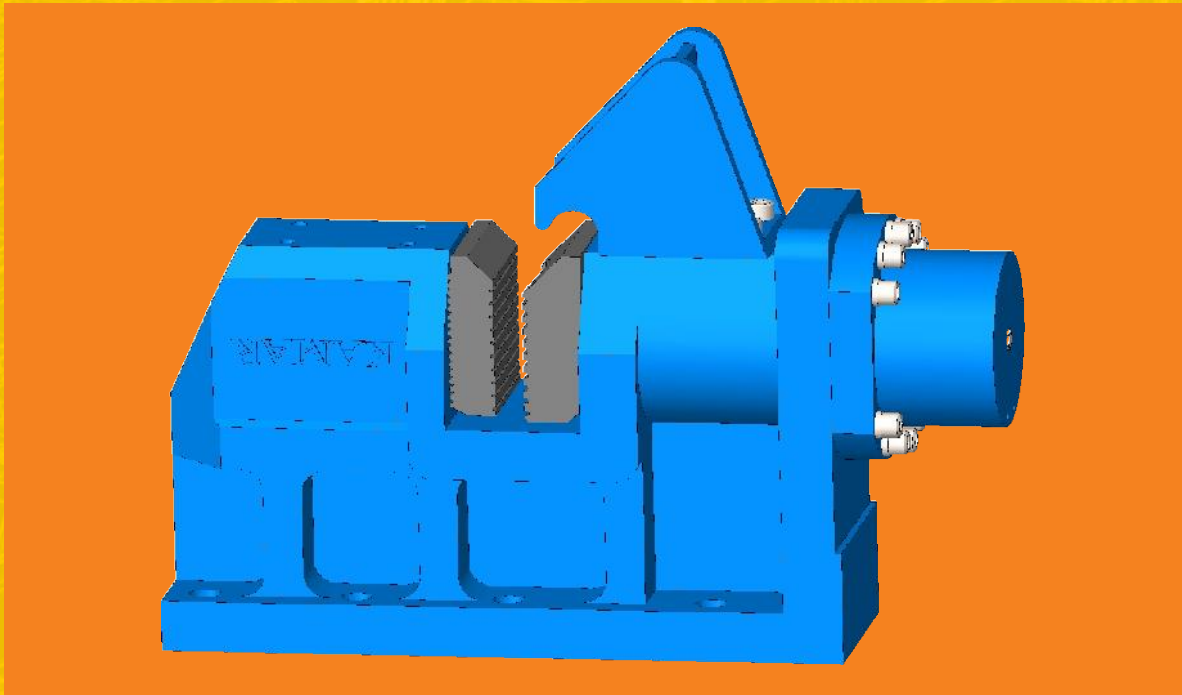

## K-80S HYDRAULIC CAISSON CLAMPS FOR CASING

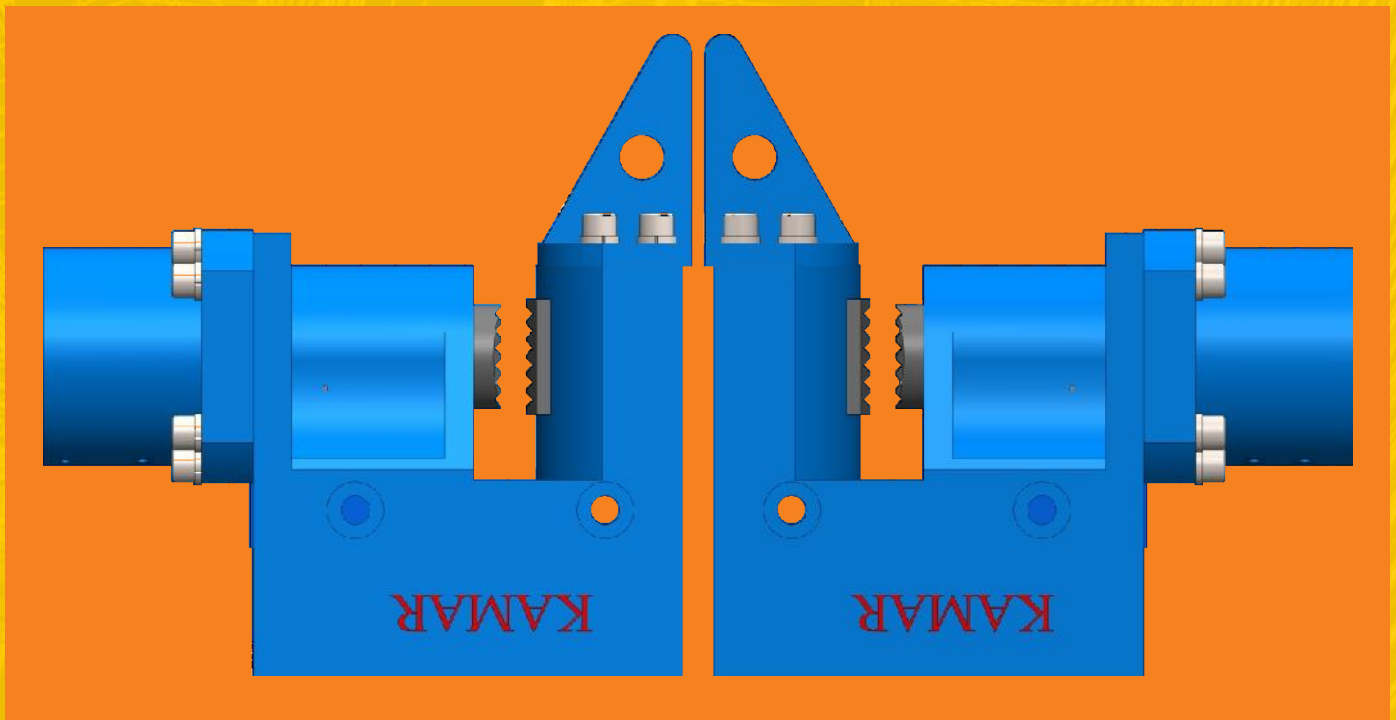

**KAMAR..... Anything else is a compromise**

*Optional: Different make of new and refurbished diesel engines are available upon requests*



**HEAD OFFICE :**

Kamar Estate, Devicha Pada, Behind Deepak Nitrite Ltd,  
Taloja MIDC, Panvel, Raigad – 410208.

---

**CORPORATE OFFICE :**

20, Hussain Patel marg, Wadi Bunder, Mazgaon, Mumbai - 400010.

---

Tel.: +91 9821831097, +91-22-27410768 | Email : info@kamargroup.com

**[www.kamartools.com](http://www.kamartools.com)**