

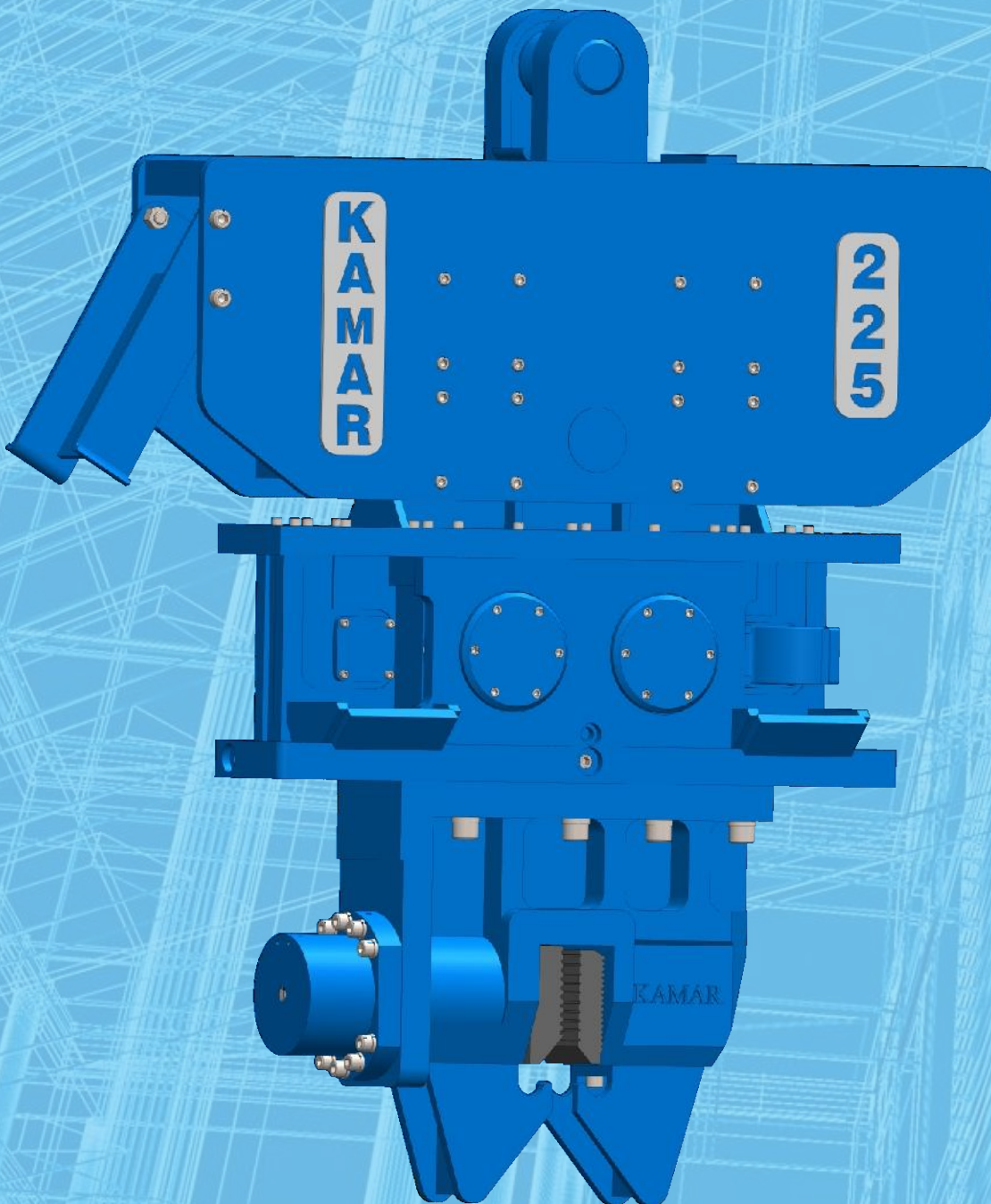

ASIA'S ONE STOP FOUNDATION SHOP

KAMAR VIBRATORY HAMMERS

SALES • RENTAL • PARTS • SERVICE





KAMAR INFRASTRUCTURE PVT. LTD.

KAMAR INFRASTRUCTURE PVT. LTD. began in 2005 continuing a tradition of innovation. Today, we continue to dominate the Asian market for vibratory driver/extractors with its line of powerful and more reliable hydraulic powerpacks. Our in-house brand **KAMAR** and its logo is a trademark of assurance and confidence that is very well recognised in the local construction industry. Each **KAMAR** vibratory driver/extractors and powerpacks provides impressive driving and pulling capabilities.

In recent years, we have developed the capability of building our own hydraulic powerpacks to meet the harsh and humid conditions of construction sites of this generation. The combined configuration offers contractors significant economies with the ability to meet a diversity of requirements with one hammer with multiple energy ratings.

Kamar Infrastructure's past triumphs continues a tradition of commitment to manufacturing and marketing the very best pile driving equipment anywhere. Our principles of simplicity of design, reliability of performance and durability for exceptionally long service life continue to be central to our business. These values resonate with contractors and engineering firms worldwide.

Every **KAMAR** equipment has been the result of listening to and working in partnership with customers. For decades, Kamar Infrastructure has responded time after time: inventing and perfecting tools and equipment to meet customers' requirements for advanced solutions to seemingly impossible technical challenges.

Kamar Infrastructure's attention to customer service continues to perfect its lines of equipment and interchangeable components. The goal, to enable customers to accomplish more at lower cost with their investment in **KAMAR** equipment.

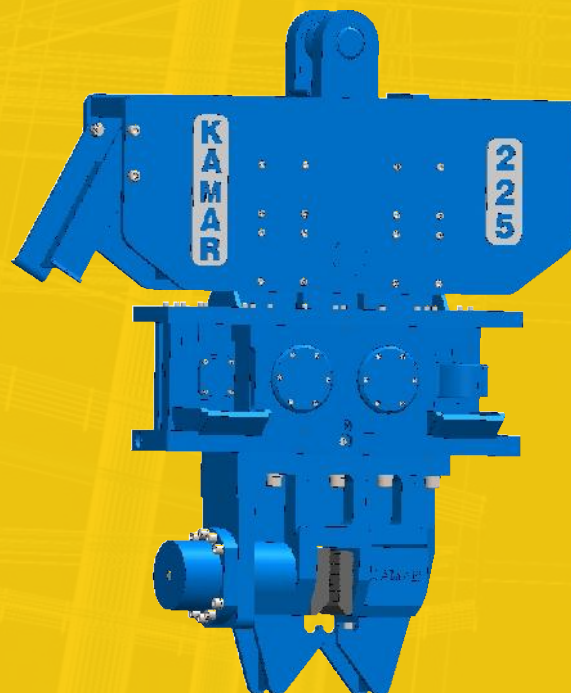

KVH-225 HYDRAULIC VIBRATORY HAMMER

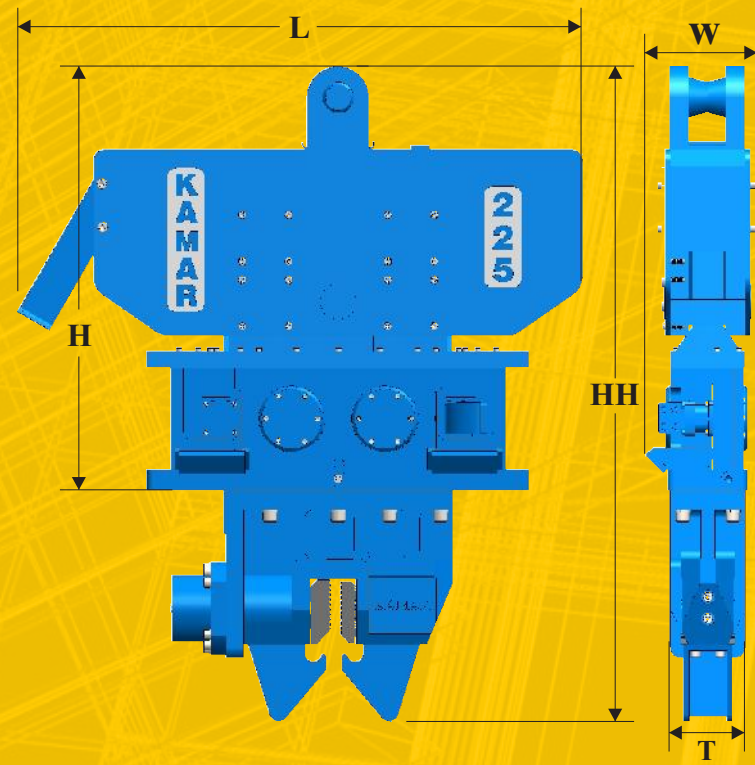

Eccentric Moment	1100 in lbs (12.7 kgm)
Frequency	2300 vpm
Centrifugal Force	83 tons (735 kN)
Amplitude (Free Hanging)	0.81 in (21 mm)
Max Line Pull For Extracting	40 US ton (355 kN)
Weight (No Clamps & Hoses)	4,600 lbs (2087 kg)
Non-vibrating Weight	1,900 lbs (862 kg)
Height Without Clamp (H)	68 in (1727 mm)
Height With Clamp (HH)	105 in (2667 mm)
Length Incl. Hose Chute (L)	91 in (2311 mm)
Width (W)	18 in (457 mm)
Throat Width (T)	12.2 in (310 mm)
Hydraulic Hose Length	100 ft (30 m)
Hydraulic Hose Weight (w/o oil)	850 lbs (385 kg)

KPP-252 POWERPACK



Engine : 6BT (Cummins)
 Max. Drive Flow : 356 liters / min
 Max. Drive Pressure: 320 bar
 Power : 165 HP
 Operating Speed : 2500 rpm

- Conceal Exhaust Silencer And 4 Lifting Eyes
- Stainless Steel Latches & Hinges Operating Speed : 2500 rpm
- Noise Reduction Panels
- External Fuel & Hydraulic Tank Inspection Allocations
- 3000 (l) X 1420 (b) X 1930 (h)
- 4 Ton (approx.)

CLAMPS

K-126S HYDRAULIC UNIVERSAL CLAMPS FOR SHEET PILE

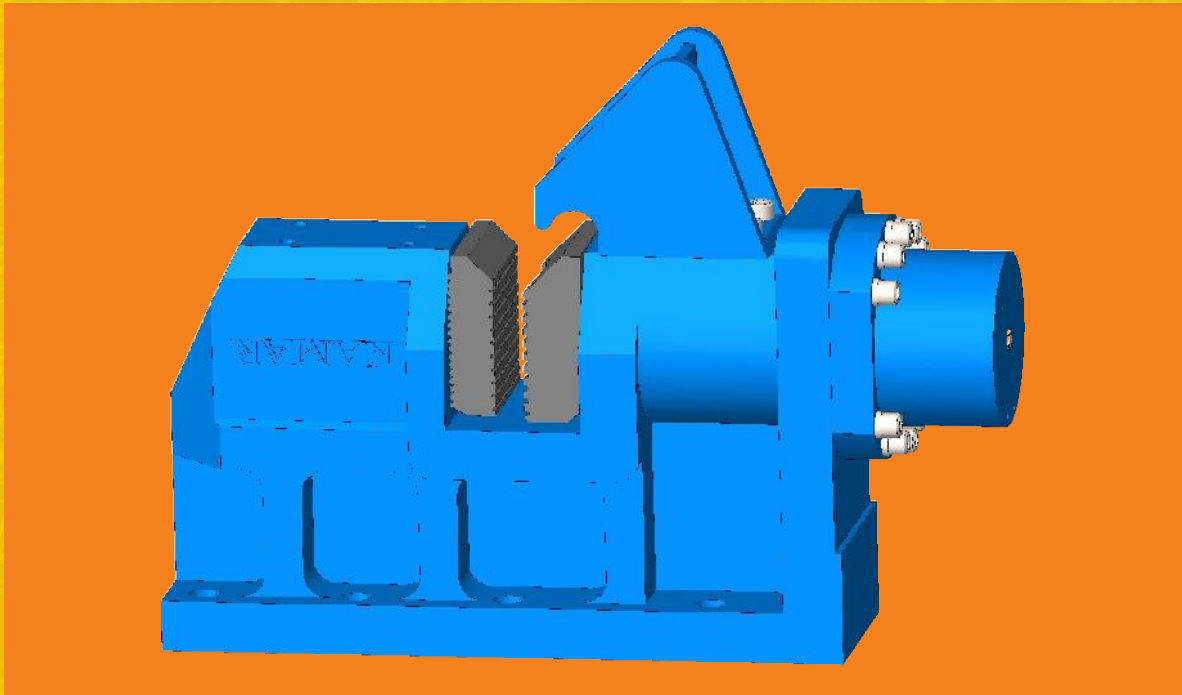

K-80S HYDRAULIC CAISSON CLAMPS FOR CASING

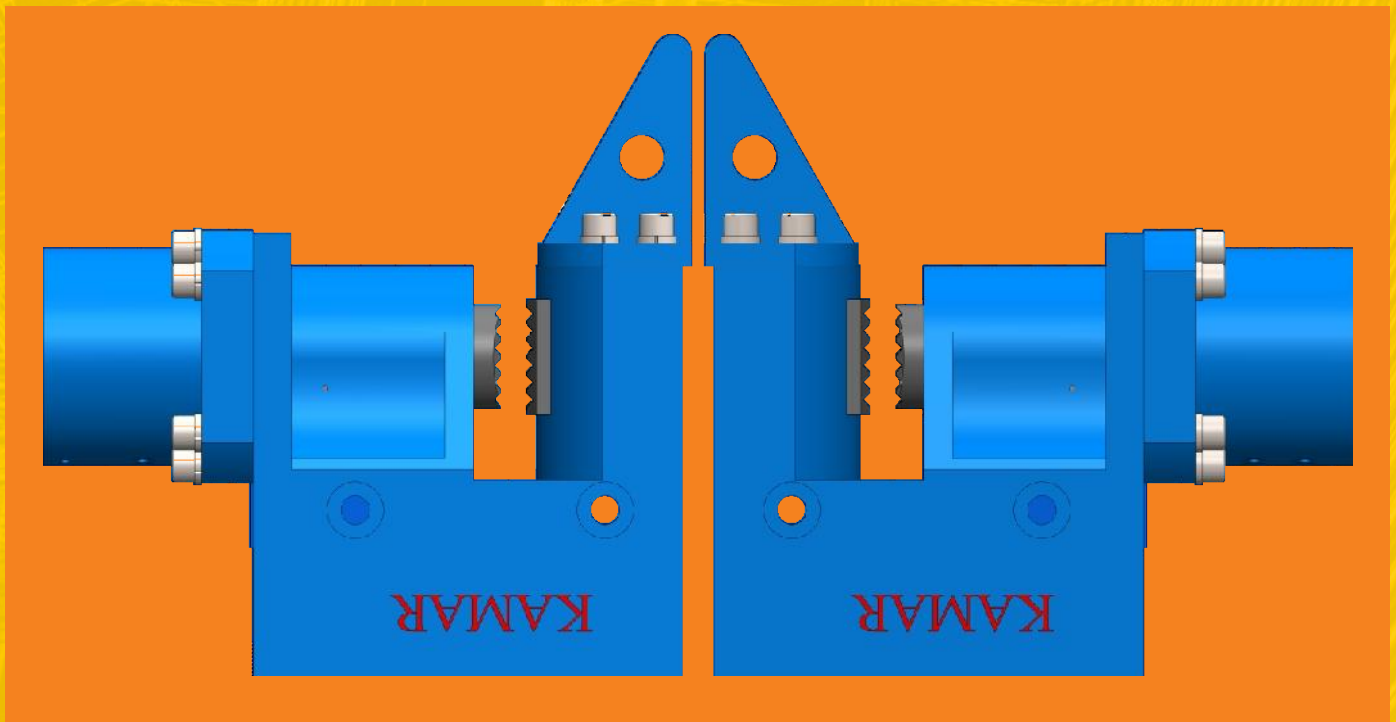

KAMAR..... Anything else is a compromise

Optional: Different make of new and refurbished diesel engines are available upon requests



HEAD OFFICE :

Kamar Estate, Devicha Pada, Behind Deepak Nitrite Ltd,
Taloja MIDC, Panvel, Raigad – 410208.

CORPORATE OFFICE :

20, Hussain Patel marg, Wadi Bunder, Mazgaon, Mumbai - 400010.

Tel.: +91 9821831097, +91-22-27410768 | Email : info@kamargroup.com

www.kamartools.com